



ONE-STOP  
INDUSTRIAL  
SOLUTION  
PROVIDER



# CONTENTS

- COMPANY OVERVIEW

- CEMENT INDUSTRY

- BULK MATERIAL HANDLING

- MECH - ELEC - INST

- AVIATION

- INDUSTRIAL SERVICES

Munir Associates is one-source industrial solution provider for all your requirements. As an expanding engineering company, Munir Associates has stood for quality, reliability and flexibility and has earned an industry wide reputation for excellence with goal to deliver the most usable, cost effective & accurate solutions to some of the most critical industrial problems.

Munir Associates, with the help of its experience spanning over many years and hundreds of projects, guarantees uncompromising expertise and end-to-end solutions to a wide range of clients in following industries:

- Cement
- Power
- Fertilizer

### GLOBAL PRESENCE

Munir Associates serves Middle East, South Asia, Africa and other regional markets through its offices in 4 countries

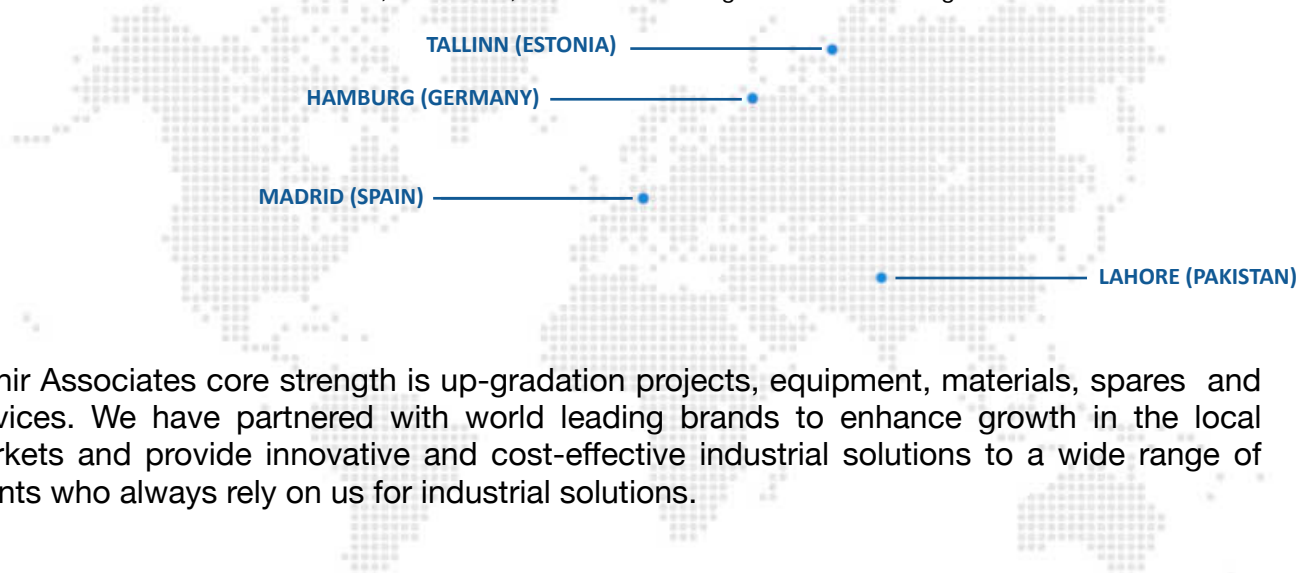

Munir Associates core strength is up-gradation projects, equipment, materials, spares and services. We have partnered with world leading brands to enhance growth in the local markets and provide innovative and cost-effective industrial solutions to a wide range of clients who always rely on us for industrial solutions.



**Munir Associates** vision is to be the most successful and respected industrial equipment supplier globally. To achieve this goal, we partner actively with manufacturers and our customers to provide innovation and sustainable technical solutions, to help them increase productivity, reduce costs and minimise risks.

We offer our customers a complete service package which includes planning, supply, installation, commissioning, training, documentation, and where needed annual maintenances and supply of spare parts.

- Our core mission is to ensure that our customers get the best possible added value to their operations from products and services we deliver
- We aim to constantly widen our product range so that our customers can get much of their needed products and services from one supplier, Munir Associates
- We aim to be the supplier who gives our customers more possibilities from one place.

# CLIENTS



# CEMENT INDUSTRY

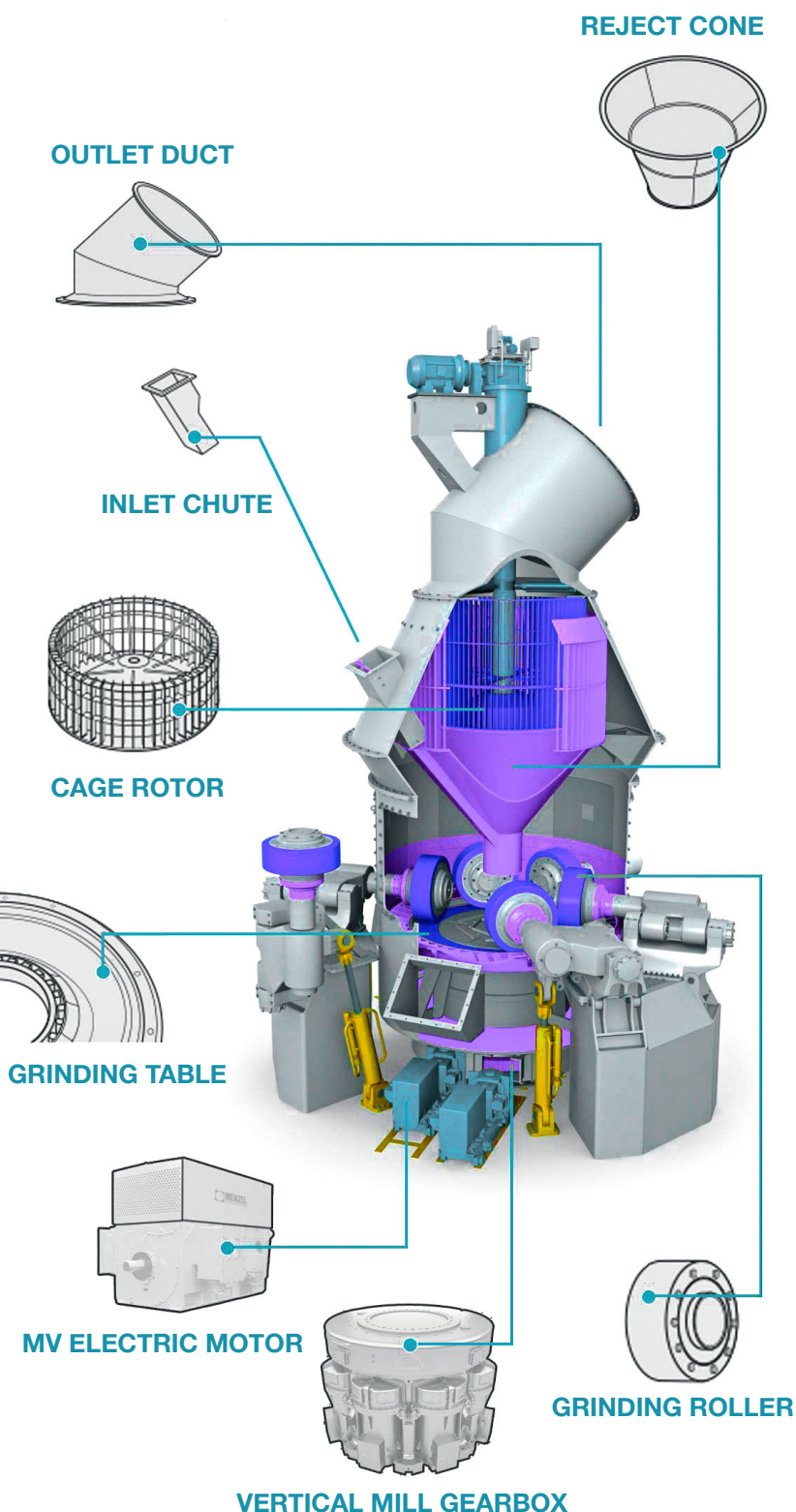

Experience of Munir Associates team spanning over many years, guarantees uncompromising expertise in special wear-resistant and heat-resistant casting items for different areas of cement production line:

- CRUSHER
- VERTICAL GRINDING MILL
- BALL MILL
- KILN
- PREHEATER
- COOLER

## Crusher

- Rotor
- Hammer Dish
- Limestone Crusher Hammer
- Hammer Bolt
- Complete Rotor
- Wear plate for Crusher

## Vertical Grinding Mill

- Tyre segments
- Table segments
- Separator
- Separator Fins
- Dam ring
- Scatter ring

## Ball Mill

- Diaphragm
- Cement mill Liners
- Bolts

## Kiln

- Inlet sector
- Outlet sector
- Anchors

## Preheater

- Dip tube
- Immersion Tube

## Cooler

- Grate plate
- Cross-bar cooler profiles
- Lip seals

# BULK MATERIAL HANDLING

Munir Associates provides high-quality cost-effective bulk materials handling solutions that improves efficiency, reduces risks and delivers competitive advantages for our customers. Our quality and experience means optimum solutions for your bulk handling applications.

Cement mining industries constitute some of the most punishing environments for wear components, where durability and reliability are paramount to profitability and safety. Munir Associates can guarantee dependable solutions to support the most demanding applications.

## Bucket Elevators & Pan conveyors

We specialise in the development of turnkey high quality solutions for vertical bucket elevators and pan conveyors to clients in various industries such as cement, mining, oil & gas, steel and fertilizer sectors, covering a wide variety of materials with capacities of up to tens of thousands of tonnes per hour.

Pan conveyors customised according to client's requirements, designed to suit slopes matching the angle of repose of the conveyed bulk material. Pan conveyors covers a large range of applications, from small capacities and horizontal conveying routes to high capacities and lifts

### *Spares:*

- Single & double strand bucket elevator chains for most of the well-known OEM bucket elevators
- Drive and tail-end sprockets with shafts according to OEM part numbers
- Belt replacements in steel-cord bucket elevators
- Tail axles
- Replacement pans & buckets
- Friction bearings
- Drive units
- Electrical motors
- Other electrical & mechanical spares for pan conveyors and bucket elevators

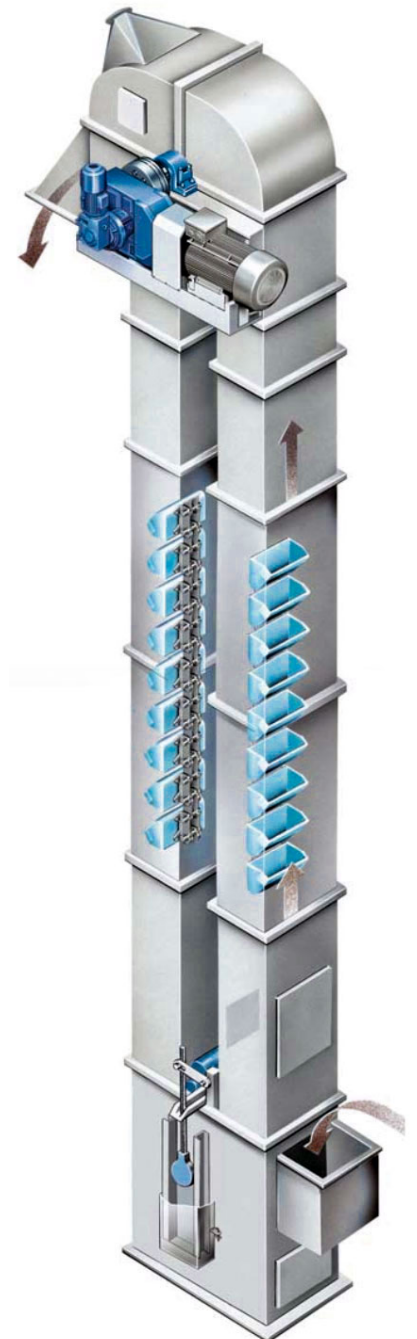



## Belt Conveyors

We assist in design and manufacturing of efficient belt conveying system with lengths from few meters up to several kilometers, covering a wide variety of materials including hot clinker as well as all kind of ore: coal, pet coke, phosphates, fertilizers, iron and other minerals.

### Spares:

- Abrasion resistant, Heat resistant, Chemical resistant and other special application rubber belts
- Steel-cord belts for long distance conveyors
- Idlers and Rollers (Impact, Return, Guide rollers), Motorized pulleys
- Primary and Secondary Belt cleaners/scrapers
- Vulcanizing presses, vulcanising material & toolkits
- Quick fix & repairing solutions
- Electromagnetic separators & metal detectors

### RESISTANCE

-  **ABRASION RESISTANCE**
-  **ANTI-STATIC**
-  **COLD RESISTANCE**
-  **FIRE RESISTANCE**
-  **HEAT RESISTANCE**
-  **OIL RESISTANCE**
-  **OZONE & UV RESISTANCE**
-  **RIP & IMPACT RESISTANCE**

## Stockyard Machinery - Stackers & Reclaimers

We provide turnkey solutions for stockyard machinery including fixed and travelling stackers, circular and longitudinal stockyards, combined bucket wheel stacker reclaimers, to various industries such as cement, mining, oil & gas, fertilizer and steel sector.

### Spares:

- Side-scraper / Reclaimer chains
- Gear boxes
- Special motorized cable reels
- Motors and other equipment

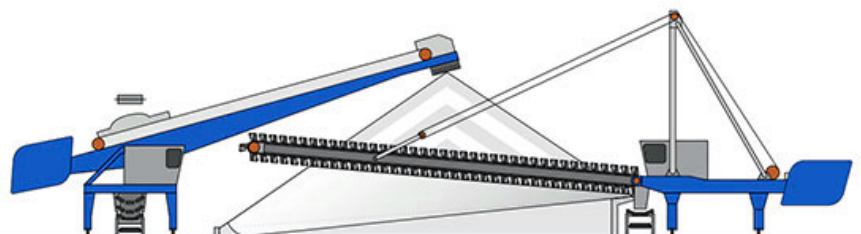

# MECHANICAL EQUIPMENT & SPARES

Being the premium business partner of many top industrial equipment manufacturers, Munir Associates provides unmatched low prices with maximum discount on list prices and shortest possible delivery period to our clients for mechanical spares. Some of the items are listed below:

- Low Pressure Screw Compressors
- Liquid Ring Vacuum Pumps
- Centrifugal Pumps
- Rotary Lobe Blowers

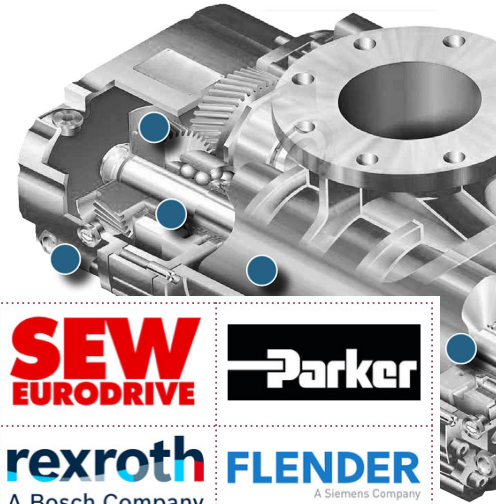

## WHY CHOOSE US?

1. Shortest possible delivery period. In many cases, availability from stock
2. Maximum discount on the list prices of standard items
3. Technical support for customised solutions according to client's requirement
4. Replacement of obsolete items with the newer, upgraded versions
5. After-sales support

- Gearboxes & Couplings
- Backstops
- Geared Motors
- Heat Exchangers / Oil coolers
- Valves
- Special Seals
- Compressors
- Metering pumps, Grease pumps
- Dosing pumps, Gear pumps
- Actuators
- Bearings
- Industrial fans
- Air Cannons & Multiport Blasters
- Complete Weigh Feeders
- Pneumatic Parts
- Special Hoses
- Gas Analysers
- Wear resistant materials

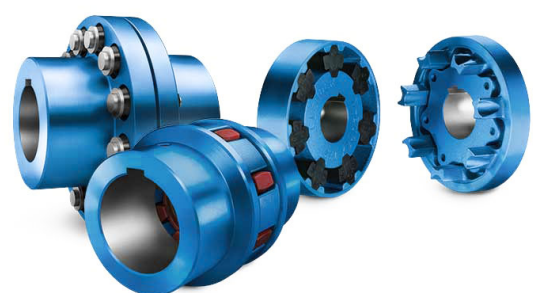
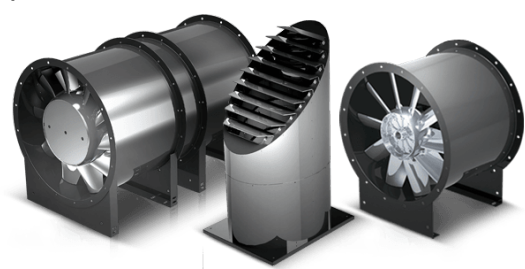
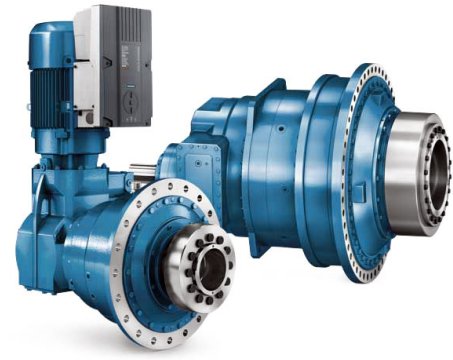

<b>SEW EURODRIVE</b>	<b>Parker</b>
<b>rexroth</b> A Bosch Company	<b>FLENDER</b> A Siemens Company
<b>AERZEN</b>	<b>HAWES HYDRAULIK</b>
<b>HS-Cooler GmbH Wittenburg</b>	<b>ROBUSCHI</b>
<b>Steinel</b>	<b>Donaldson FILTRATION SOLUTIONS</b>
<b>maag</b> a DOVER company	<b>HARDOX WEAR PLATE</b>
<b>LINCOLN SKF</b>	<b>RULMECA</b>
<b>martin engineering</b>	<b>KRACHT</b>
<b>GEFA PROCESSTECHNIK GMBH</b>	<b>Sumitomo</b>
<b>Gardner Denver</b>	<b>EagleBurgmann</b>
<b>SPXFLOW</b>	<b>VOITH</b> Engineered Reliability
<b>VEGA</b>	<b>HYDAC</b>
<b>ALFA LAVAL</b>	<b>ALIMAK</b>
<b>RENK</b>	<b>AAF INTERNATIONAL</b>

# ELECTRICAL & AUTOMATION

Munir Associates (*Division of Electrical & Automation/Instrumentation*) is your first point of contact for all your requirements of electrical equipment, replacement spares and up gradation queries. Some of the items are listed below but this list is not exhaustive:

- LV/MV Industrial Motors
- Circuit Breakers
- Solenoid Valves
- Power & Control Cables
- Festoon systems / Electrification
- Electric Hoists
- Relays & Fuses
- Carbon Brushes & Holders for Elec. Motors
- Laboratory Ovens
- Electromagnetic Separators
- Metal detectors
- Touch screens PLC
- Networking Modules
- High-temperature kiln cameras
- Special application cooler cameras
- Electromagnetic Flow meters
- Vibration meters
- Speeds sensors
- Load cells for weighing bridges
- Other industrial electrical, instrumentation & automation equipment

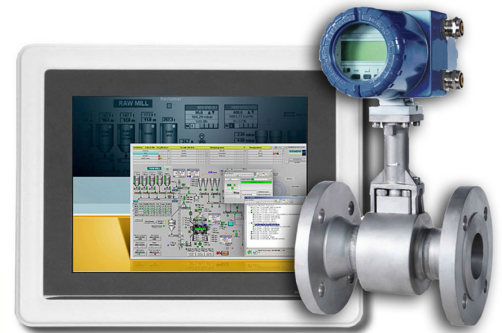

Note: All trademarks, logos and images remain property of their respective owners, and are used only for illustration purpose to describe the products being offered.



# AVIATION



**Beechcraft**



**Hawker**

**Piper**

Our aviation team is focused on providing whatever it takes to get you back on schedule. They're experts at finding and providing every part you need so you can spend more time in the air and less time shopping around.

In partnership with one of Europe's leading supplier for aircraft spare parts and components for several brands, we sell General Aviation spare parts worldwide. We offer parts from stock of approx. 30,000 spares & aviation related products – ranging from screws to premium-quality exchange components.

Thanks to our wide-spread industry network and efficient logistics we also procure non-stock items on short notice.

- Mainly aircraft spare parts and wares for Embraer, Cessna, Beechcraft, Hawker and Enstrom Helicopter
- Several spare parts for Cirrus, Piper, Mooney and Diamond Aircraft

BATTERIES, LIGHTING, ELECTRICAL AND AVIONICS	AIRFRAME, WINDOWS, WINDSHIELD AND DE-ICING	HOSE AND HOSE ASSEMBLIES	HYDRAULIC POWER	POWERPLANT, IGNITION, FUEL SYSTEMS AND FILTERS	TIRES, TUBES, WHEELS AND BRAKES
<ul style="list-style-type: none"> <li>• Airlock</li> <li>• B/E Aerospace</li> <li>• GKN</li> <li>• Goodrich</li> <li>• Lee Aerospace</li> <li>• PPG</li> </ul>	<ul style="list-style-type: none"> <li>• Artex</li> <li>• Concorde</li> <li>• General Electric</li> <li>• Gill</li> <li>• Securaplane</li> <li>• Whelen</li> </ul>	<ul style="list-style-type: none"> <li>• Aeroduct</li> <li>• Aeroquip</li> <li>• Bemco</li> <li>• Flexfab</li> </ul>	<ul style="list-style-type: none"> <li>• Eaton</li> <li>• Lycoming</li> <li>• Pratt &amp; Whitney</li> </ul>	<ul style="list-style-type: none"> <li>• Airborne</li> <li>• Barry</li> <li>• Bracket</li> <li>• Champion</li> <li>• Eaton</li> <li>• Goodrich</li> <li>• Honeywell</li> <li>• Lycoming +</li> </ul>	<ul style="list-style-type: none"> <li>• ABS</li> <li>• Condor</li> <li>• Dunlop</li> <li>• Goodrich</li> <li>• Goodyear</li> <li>• Meggitt</li> <li>• Michelin</li> <li>• Parker</li> <li>• Scott +</li> </ul>

# SERVICES

Munir Associates, in partnership with some of the leading service companies in the industry, provides following services to our clients:

- I. Gearbox Inspections
- II. Material Flow Optimization
- III. On-site Conveyor Rubber Belt Splicing
- IV. Hot Kiln Alignment
- V. Kiln Shell Profile and Shell Crank Survey
- VI. Girth Gear Reversal Supervision
- VII. Kiln Shell Ovality Testing
- VIII. Upgradation study and Feasibility etc.

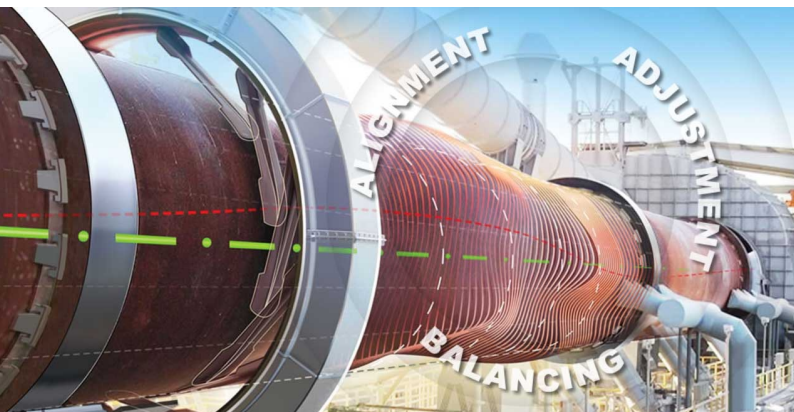

**HOT KILN ALIGNMENT,  
SHELL PROFILE  
MEASUREMENTS,  
COMPREHENSIVE KILN  
INSPECTION AND SUPERVISION  
OVER ROLLERS ADJUSTMENT**

Rotary kiln alignment is well known preventive maintenance tool. The rotary kilns are affected by mechanical and technological stresses causing components wear and as consequence misalignment. Every kiln user wish to have high run-time factor and no unexpected fails and stoppages. Therefore the managers prefer preventive routines than costly repairs.

Munir Associates is a leading kiln alignment service provider. Our scope of works and quality of services fits the highest available standards. The kiln axis survey and adjustment, rollers position and profiles, shell deformation analysis and 3D modelling, radial and axial run-out of tires and girth gear, shell crank detection, kiln thrust balancing, drive mesh inspection, finally complete recalculation of kiln mechanical parameters, all in one comprehensive kiln inspection report.

Measurements of rotary kiln shell deformation constitute a significant part of our extensive offer of kiln inspection. We covering the scope ranging from simple measurements of distance and geometric approximation of a cross-section shape, to linear laser scanning and unique computer software development enabling the calculation of shell eccentricity in a particular cross-section and its shape deformation (circularity).



- I. Hot kiln alignment survey
- II. Kiln shell profile and shell crank survey
- III. Kiln shell ovality test (direct survey of elastic deformation of the kiln shell)
- IV. Kiln drive system geometry: girth gear, pinion, shafts, reducer, engine
- V. Recalculation of kiln mechanical parameters
- VI. Supervision of adjustment action to be carried out by technicians of the Plant

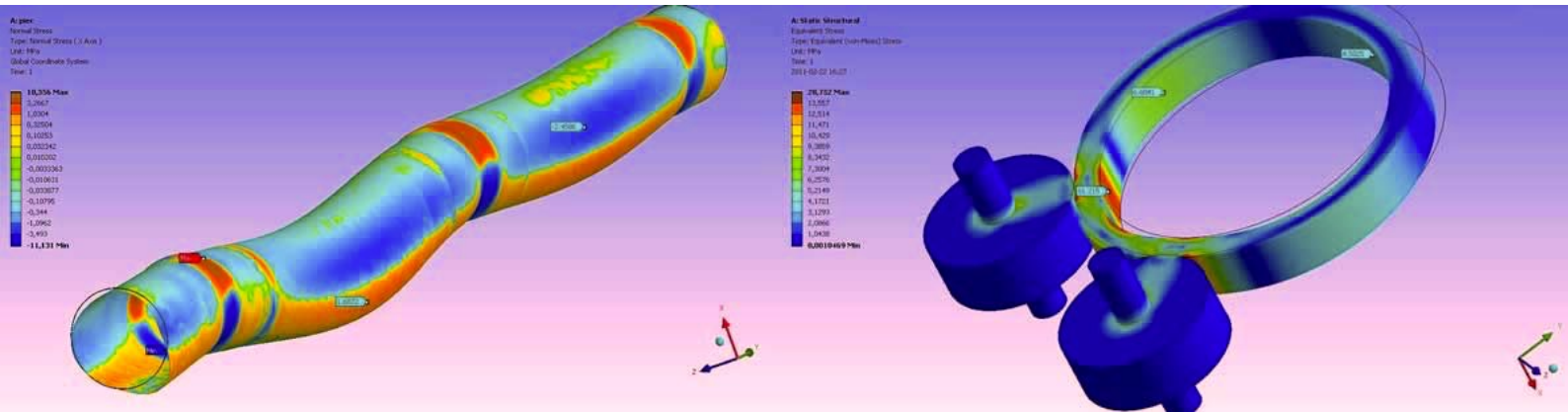

We know from our practice, events when a kiln frequently has bearing overloads (hot bearings), shell cracks, roller shaft cracks, frame cracks in spite of measuring alignment and adjustment. In these cases, the kiln should be again mechanically verified. This process is reverse to design: the same parameters are checked but the kiln is real, and the process is based on real dimensions and production parameters. There are cases of an uneven distribution of support loads with simultaneous dimensional over-design for stress the kiln shell, which lets the kiln axis position optimise. This technique has been known by producers for many decades but it is not widely offered.

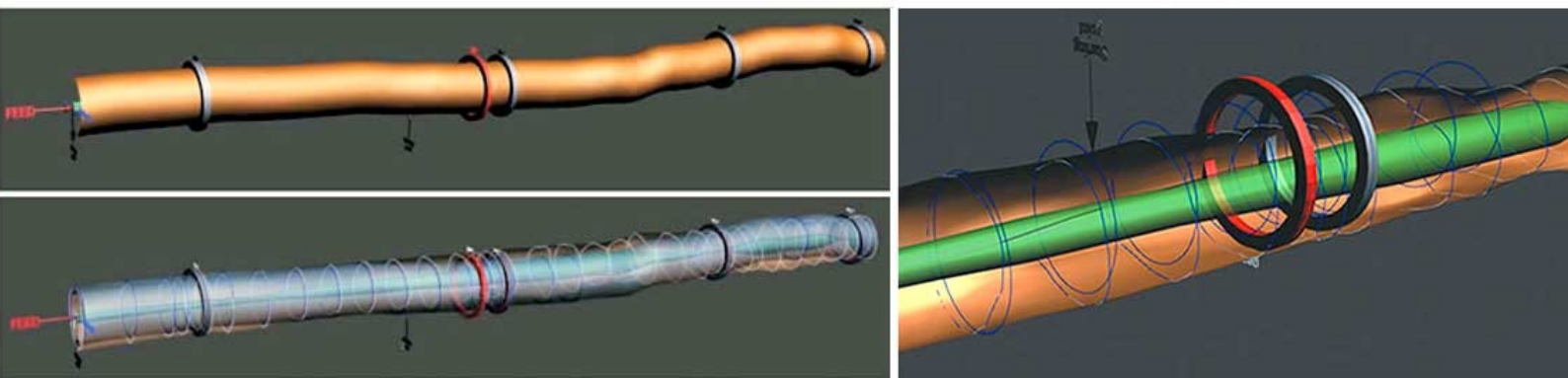

# GLOBAL PARTNERS

Munir Associates has partnered with world-renowned industrial brands and officially represent following companies as sole authorised representative for Pakistan market



**KETTENWULF** is Europe's biggest manufacturer of engineered chains, drive chains and sprockets. With currently 10 production facilities / sales offices worldwide, KettenWulf provides individual solutions in the field of technical conveying and drive systems to customers around the world.

Products: High quality industrial chain manufacturer. Bucket elevators, Apron conveyors, Hinged conveyors, Pan conveyors, Trough chain conveyors, Scraper / reclaimers systems



**ROBUSCHI spa** – international leader in the manufacturing of positive displacement blowers, low-pressure screw compressors, vacuum pumps and centrifugal pumps – has been involved in product development for 7 decades now.

Products: Blowers, Vacuum pumps, Centrifugal pumps and Compressors



**CONDUCTIX-WAMPFLER**, fully owned by Delachaux Group, serves the world's largest material handling, automation, mass transit customers and is the world leader in the design and manufacture of efficient energy and data transmission systems for all types of mobile equipment and machinery. Conductix-Wampfler

Products: Motor driven reels, Cables, Conductor rails, Cable festoon systems, Data transmission systems



**RULMECA GROUP** is the world's largest supplier of rollers/idlers and motorized pulleys for heavy duty belt conveyors for quarries and mining applications.

Products: Rollers and stations, Motorized pulleys, Belt tracking rollers, Idlers, Conveyor Pulleys.



**DUNLOP** Conveyor Belting (Europe) is part of Fenner Dunlop Conveyor Belting Worldwide, the world's leading conveyor belt manufacturer. With twelve manufacturing plants on five continents, the Fenner Dunlop Group provides the most complete range of top quality conveyor belts in the world.

Products: Abrasion and Heat resistance conveyor belts, Steel-cord conveyor belts, Steel-cord belts for bucket elevators



**HS-COOLER GmbH Wittenburg** has been developing, manufacturing and selling high-quality, innovative, high-performance heat exchangers for industrial and maritime usage for many years. Their heat exchangers are used in every imaginable setting, fulfilling the cooling requirements of engines and working machines as well as refrigeration engineering.

Products: Heat exchanger, Gascooler – Aircooler, Vaporiser, Condenser, Preheater



**MARTIN ENGINEERING** pioneered the invention of Air Cannon systems. With 11 business units and several production facilities worldwide, Martin Engineering is among the leading material flow solution provider focused on mining, aggregate, cement production and coal-fired power as well as the Food Processing, Port & Transportation, Biomass, Pulp & Paper and Steel industries.

Products: Air cannons, Multiport air blasters, Belt cleaners, Trackers, Tensioners, Dust management solutions, Transfer point solutions, Sonic Horns.



**ERIEZ MAGNETICS** is a world authority in advanced technology for magnetic, vibratory and inspection system applications. Eriez designs, develops, manufactures and markets magnetic separation, metal detection and materials feeding, screening, conveying and controlling equipment for process and metalworking industries.

Products: Magnetic separators, Metal detectors, magnetic material handling equipment



**BRADKEN** is a leading global supplier of differentiated consumable and capital products to international markets. Bradken employs over 6,000 people globally and operates 59 manufacturing, sales and service facilities throughout Australia, New Zealand, the United States of America, Canada, China, Malaysia, South Africa, Indonesia, South America and the United Kingdom.

Products: Bradken is a leading international supplier of high quality Mill Liner systems to suit AG/SAG Mills, Rod Mills, Cement Mills and Ball Mills.



**ANDRITZ GROUP** is a globally leading supplier of plants, equipment, and services for hydropower stations, the pulp and paper industry, the metalworking and steel industries, and solid/liquid separation in the municipal and industrial sectors. ANDRITZ offers technologies for certain other sectors including automation, the production of animal feed and biomass pellets, pumps, machinery for nonwovens and plastic films, steam boiler plants, biomass boilers and gasification plants for energy generation.



**IRIS FRANCE**, as European leader of the refractory anchor manufacturing, produces and distributes a large range of refractory products, covering all industrial needs. Iris France offers more than 200 standard types, and in addition, all the specials which have been designed on request.

Products: Anchors for castables, Anchors for fibers, Brick anchors, Support brackets



**REFRACTA**, since 1940, has been an international benchmark in the development of refractory products for the process industries. Best specialists in refractory technology and decade of experience in the industry enables Refracta to offer the most advanced technical solutions to solve specific problems faced by clients

Products: High alumina, Precast and Fireclay refractories. Regular/Dense/No Cement castables. Insulations



**MIRION TECHNOLOGIES (Formerly IST)** has a long history of providing mission critical products to detect, monitor and identify radiation. Mirion is comprised of five divisions: Health Physics, Radiation Monitoring Systems, Sensing Systems, Dosimetry Services, Imaging Systems and operates 13 production facilities in North America, Europe, and Asia.

Products: Imaging systems, High temperature kiln cameras, Sensing systems, Radiation monitoring systems, Dosimetry systems



**ESTANDA** has a production capacity of 8.000 tons/year or almost 10% of the total Spanish production of castings, specialised in the cement manufacturing industry, developing complete engineering solutions for the optimisation of all types of clinker coolers, raw/cement milling circuits.

Products: Manufacturer of Casting items. Hammers, Diaphragms, Liner plates, Inlet feed chute, Inlet headwall liners, Water injection



**RENK** is one of the world's leading industrial gear unit supplier to cement, mining, marine and other industries. The absolute precision and reliability of the mill gear units are a basic requirement for efficient production and that's why mill planners and operators around the world trust drive solutions from RENK.

RENK mill gear units are the classic drive solution for medium and large vertical mills for coal, raw material, bricks, and minerals. RENK has also developed special COPE drive system for Loesche VRM

Products: Gear Units, Condition monitoring, Test units, Gear Couplings, Safety Couplings



**TSURUMI PUMP** is a leading Japanese pump manufacturer. Since its foundation in 1924, Tsurumi has developed and marketed more than 10,000 products in Japan and all over the world.

Products: Submersible pumps, Engine driven pumps, Utility pumps



**BARBIERI COSTRUZIONI MECCANICHE** has been operating in the national and international markets for more than 100 years, constantly meeting industry's needs for development, design and construction of machinery for bulk and packaged materials handling.

Products: Rubber belt conveyors, Chain conveyors, Movable conveyors, Bucket chain elevators, Powered roller conveyors, Roller/Chain diverters



**ECORPORATES** is an international industrial service provider offering a wide range of high-quality European mechanical engineering components and associated technical and logistics services.

Products: Equipments, Machinery and Spare parts of European origin



**KÖPPER** is a modern, high-tech German group of companies at the forefront of roller press technology for various processes related to the fertilizer, cement, minerals and metalworking industries

Briquetting - cold and hot briquetting for metallurgical applications  
Comminution - high-pressure grinding for the cement industry as well as for size reduction in the ores and minerals industries



**GEOSERVEX** is world renowned name in the field of industrial services ranging from hot kiln alignments, adjustments and inspections to measurements of geometry and deformation of machines and equipments. at dams, bridges. Measurements of displacement of structures and constructions like dams and bridges.

Products: Engineering services, Hot Kiln alignment



**TAIHEIYO GROUP** has acquired the technology and know-how through toil and hardship for the past 100 years and provides the clients with modern and outstanding technology as an engineering firm affiliated to cement manufacturer. Taiheiyo currently provides system engineering services on environmental measures toward energy conservation and waste recycling.

Products: Reinforces suspension preheater, Chlorine bypass system, Pregrinding system, Control system for Cement plant



**ASSALUB** develops, manufactures and markets equipment for handling of lubricants as well as centralised lubrication systems and components for said systems. All Assalub products are known to represent a very high quality standard.

Products: Central lubrication systems, Lubricants handling, Grease pumps



**PAM** started as POUL ANDERSENS MASKINFABRIK in 1935, where the focus was the production of rotary valves and solutions for pneumatic transport of bulk materials. PAM offers consulting, design and implementation of bulk-related solutions, where the complexity of deliveries spans everything from standard systems to projects with a substantial content of 'engineering' and external collaborations

Products: Easyclean rotary valves, Screw conveyors, Screw conveyors with product distribution & rotary valves



**MENZEL ELEKTROMOTOREN GMBH** is based in Berlin (Germany) and has been manufacturing electric motors for more than 85 years. It specializes in the delivery of large electric motors, including special models, complying with the latest European standards, within the shortest possible time.

Menzel Elektromotoren is also OEM of world renowned suppliers. All the motors and components are of German origin, manufactured in Menzel Elektromotoren's manufacturing and testing facility in Berlin, Germany.

Products: High- and low-voltage motors, DC motors, Transformers and Frequency inverters.



**Munir Associates — 124-A Main Shadman, Lahore - 54000. Pakistan**

Tel: +92 42 37423675, 77, 78 Fax: +92 42 374 23 676

[www.munirassociates.com](http://www.munirassociates.com) [info@munirassociates.com](mailto:info@munirassociates.com)